



Operator's Manual

HC1750 TRAILER

MODEL TX163

Maximum Field Rating
1750 lb.

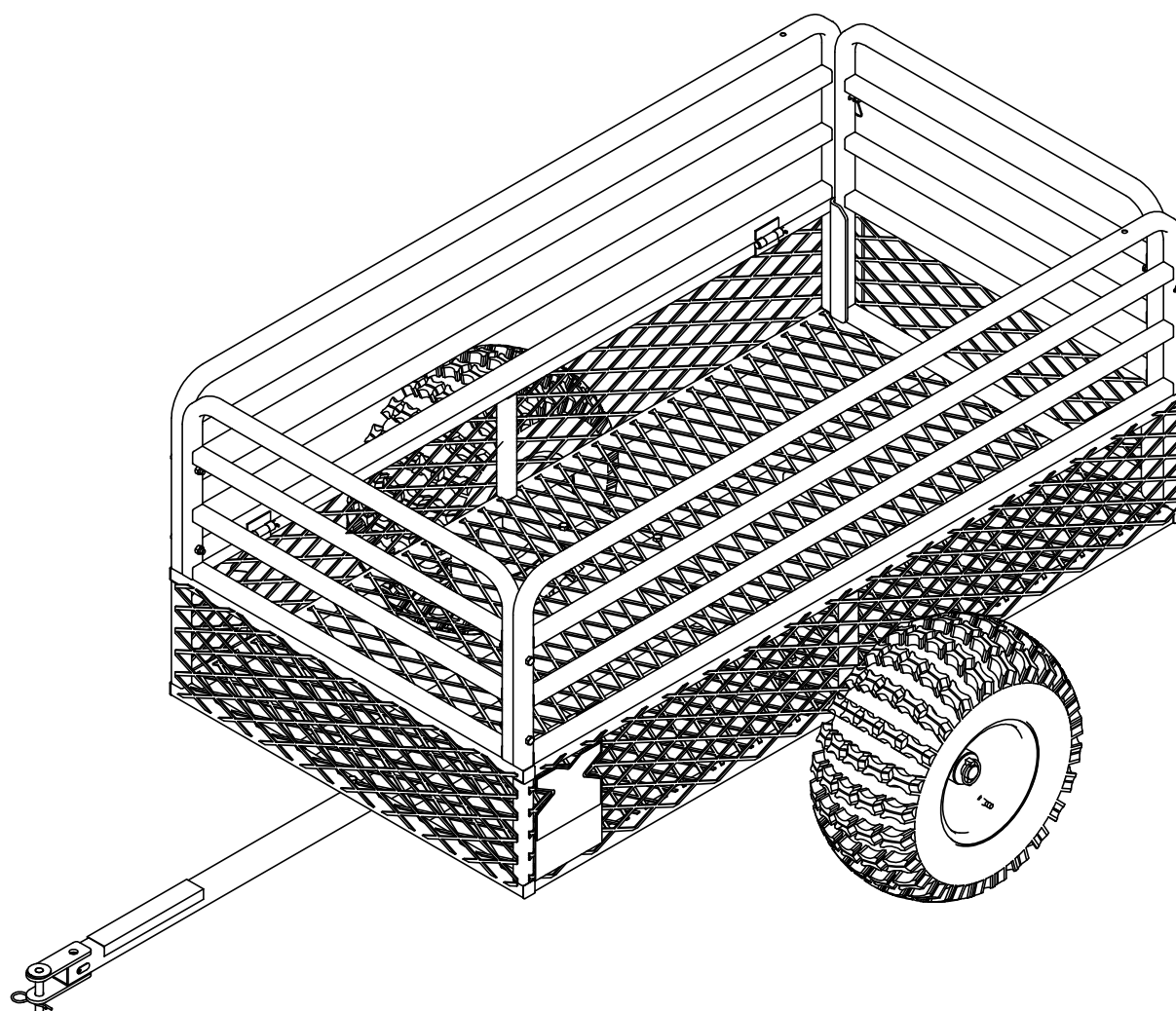

Get parts online at
www.yutrax.com

© 2020 Ardisam, Inc.
All Rights Reserved

P/N: 36746
C/N: 36741
REV1: 11/11/2020



INTRODUCTION

Yutrax™ offers a full line of engineered outdoor gear. We appreciate your purchase of our world class ATV trailer. Follow these few simple instructions and your product will be sure to give you many years of trouble free pleasure. Instructions should be kept in a safe place and reviewed at least annually. .

If for any reason you have a problem with your product or are missing any parts, **DO NOT return to the retailer**, contact the Yutrax™ Customer Service Department at 800-345-6007 for assistance.

CONTENTS

Introduction/Warranty	2
Warnings.....	3
Assembly Instructions	4-7
Parts List.....	8
Illustrated Parts Breakdown.....	9

WARRANTY

Yutrax, a division of Ardisam Incorporated, offers a one year limited warranty to be free from defects in materials and workmanship for the service life of the product, not to exceed twelve consecutive months from the date of purchase. This warranty applies to the original owner with a proof of purchase and is not transferable. This warranty applies only to products which have not been subjected to negligent use, misuse, alteration, accident or if repairs have been made by anyone outside our factory. This warranty supersedes all other warranties either expressed or implied and all other obligations or liabilities on our part. Ardisam, Inc., does not assume, and does not authorize any other person to assume for us, any liability in connection with the sale of our products. Warranty work must be sent directly to Ardisam, Inc. or one of our authorized service centers and performed by them. **To obtain warranty service and/or replacement instructions, you must have prior approval from Ardisam, Inc. before shipping your package to us by calling our customer service department at 800-345-6007 or by writing to: Ardisam, Inc., P.O. Box 666, 1160 Eighth Avenue, Cumberland, WI 54829 for a return material authorization number (RMA#).** All items must be shipped prepaid. Ardisam, Inc. will at no charge, repair or replace, at their discretion, any defective part which falls under the conditions stated above. Ardisam retains the right to change models, specifications and price without notice.

For replacement parts, phone 800-345-6007 or go online to www.yutrax.com.



READ AND UNDERSTAND THE FOLLOWING WARNINGS BEFORE ASSEMBLY

MODEL TX163

TOTAL WEIGHT LIMIT - 1750 LB.

! WARNING

! READ, UNDERSTAND AND FOLLOW ALL ASSEMBLY, INSPECTION, MAINTENANCE & USE INSTRUCTIONS PROVIDED BEFORE EACH USE. FAILURE TO FOLLOW ALL WARNINGS AND INSTRUCTIONS COULD RESULT IN SERIOUS INJURY OR DEATH.

BE SURE TO FOLLOW ALL INSTRUCTIONS PROVIDED. IF ANY INSTRUCTIONS ARE NOT UNDERSTOOD OF IF YOU HAVE PART ISSUES CALL 800-345-6007 BEFORE USING.

DOUBLE CHECK ASSEMBLY STEPS TO BE CERTAIN YOU HAVE CORRECTLY ASSEMBLED THIS PRODUCT.

! WARNING

- ! This product carries strict weight restrictions. Do Not use this product if you exceed the total weight limit.**
- ! Stopping distance increases with speed and weight of towed load. Travel slowly and allow extra time and distance to stop.**
- ! Total towed weight must not exceed limits specified in towing vehicle operator's manual.**

! WARNING

- ! Always use as an ATV trailer only.**
- ! Never tow behind vehicle on a highway. For off-road use only!**
- ! Always follow the manufacturer's recommendations for weight limits for towed equipment and towing on slopes. Excessive towed load can cause loss of traction and loss control on slopes. Reduce towed weight when operating on slopes.**
- ! Never shift to neutral and coast downhill.**
- ! Never drive in excess of 10 MPH while using this product.**
- ! Always use only approved hitches. Tow only with a machine that has a hitch designed for towing. Do not attach towed equipment except at the approved hitch point.**
- ! Never turn sharply. Use additional caution when turning or operating under adverse surface conditions. Use care when reversing.**
- ! Always inspect before each & every use to be sure there is no product damage or loose/missing bolts or hardware. Over time, nuts and bolts may become loose from vibration.**
- ! Be sure to always have the correct amount of air pressure in tires. This will help deter from unnecessary wear and/or damage. Air pressure can be found on side wall of tire.**
- ! Always be sure lock pins are latched to prevent accidental removal.**
- ! Never use a damaged ATV trailer.**
- ! Always keep bystanders away when you operate a towed attachment.**
- ! Always before you back machine and attachment, look carefully behind attachment for bystanders.**
- ! Never allow people or animals to ride in the ATV trailer! It is not designed for that matter.**
- ! Never use when intoxicated or using over-the-counter medication or prescription drugs.**
- ! Never use carelessly – Think Safety!**

HARDWARE LIST

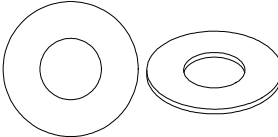
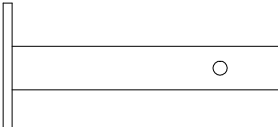
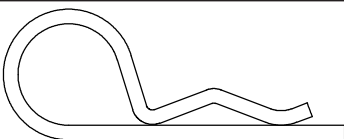
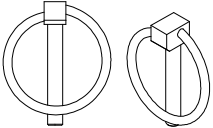
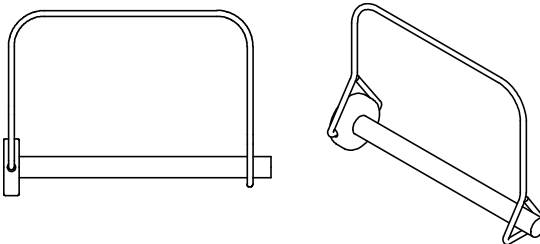
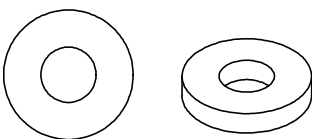
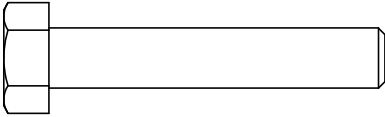
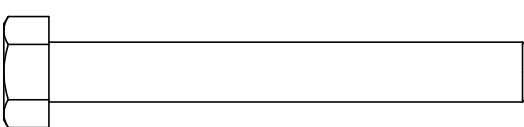
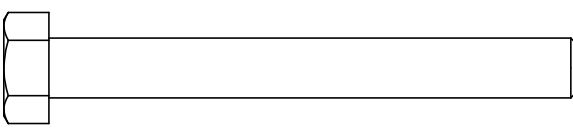
Item	Part No.	Description	Image	Qty
16	# 36535	WASHER 25 X 45 X 2.40 MM		2
17	# 25033	HITCH PIN		1
18	# 12118	HAIRPIN 1/8 IN		1
19	# 37772	LOCK PIN 6 X 40 MM		2
20	# 36790	SNAP PIN 1/4 x 3 IN		2
21	# 36789	SPACER 8.1 X 19 X 3.5 MM		2
22	# 8655B	BOLT 5/16 X 1-3/4 IN		2
23	# 53730B	BOLT 5/16 X 2-1/2 IN		4
24	# 17949	BOLT 5/16 X 18 X 2-3/4 IN		1

HARDWARE LIST (CONT.)

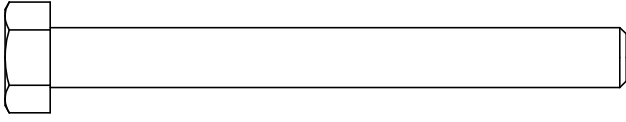
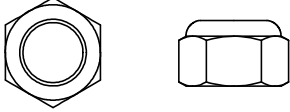
25	# 27966	BOLT 5/16 X 18 X 3-1/4 IN		3
26	# 60G5NYB	NUT 5/16 IN		10

TOOLS FOR ASSEMBLY

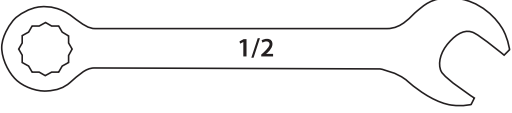
-	-	1/2 IN WRENCH		2
---	---	------------------	--	---

ASSEMBLY INSTRUCTIONS

IMPORTANT ASSEMBLY TIP:

Do not tighten any nut and bolt combinations completely until all parts are assembled together! Finger tighten plus one turn of a wrench only! This will temporarily hold the lock-nut on the bolt while helping alignment of all parts! After all parts are assembled together, all nut and bolt combinations must be completely tightened.

STEP 1

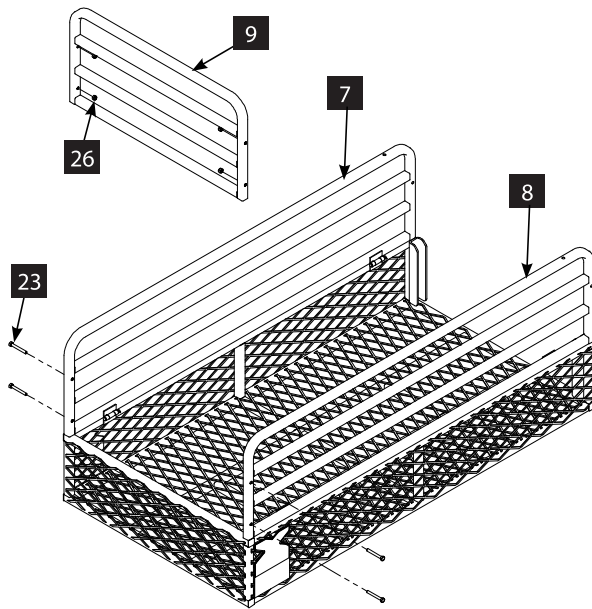

1. Fold side rail left and right (7 & 8) up and attach front rail (9) to both side rails using four 5/16-18 x 2-1/2 IN bolts and nuts (23 & 26).

STEP 2

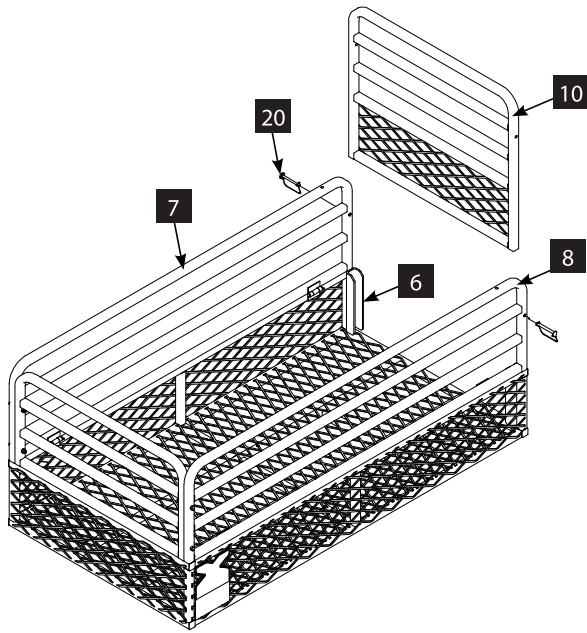

- Slide removable tailgate (10) into the brackets of the trailer bed (6) and secure to left and right side rails (7 & 8) using two ¼ x 3 IN snap pins (20).

- Attach axle (5) to trailer bed (6) using two 5/16-18 x 3-1/4 and 5/16-18 x 1-3/4 IN bolts (22 & 25) and four nuts (26).

Note: For easier assembly place unit upside down

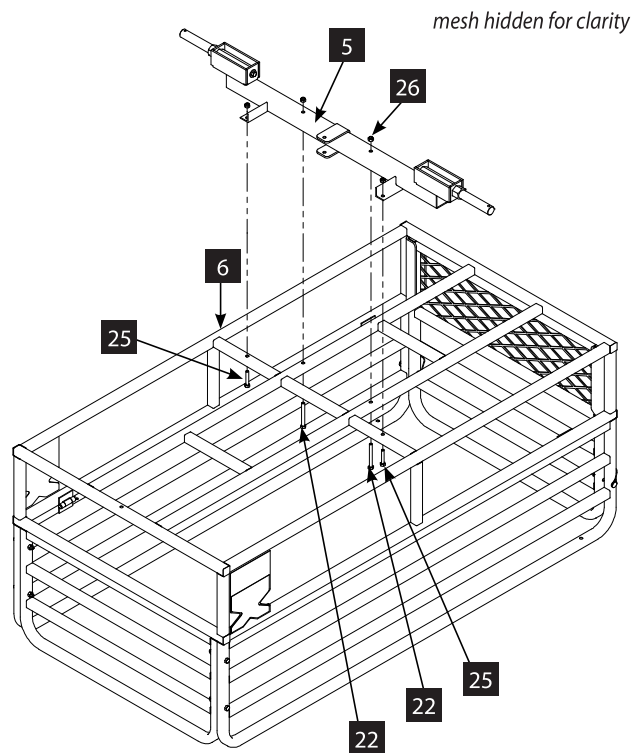

STEP 3

STEP 4

mesh hidden for clarity

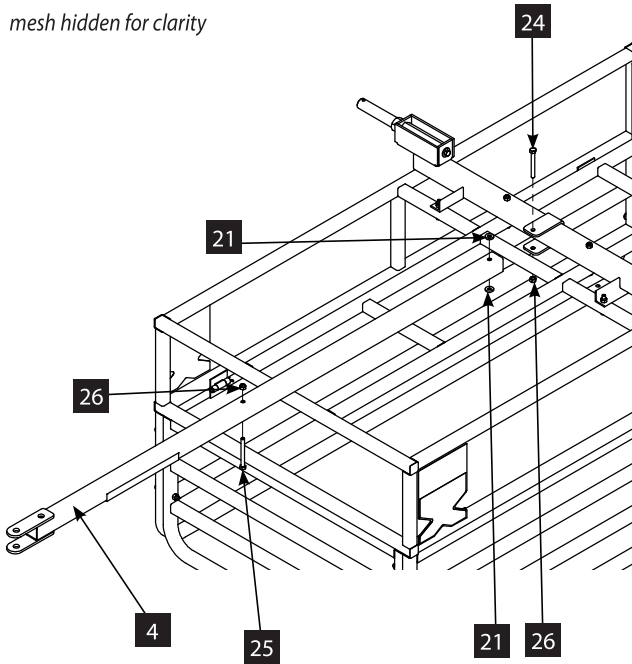

4. Attach trailer tongue to axle using one 5/16 x 18 x 2-3/4 IN bolt, two 8.1 x 19 x 3.5 MM plastic spacers, and one nut (24, 21, & 26). Attach trailer tongue to trailer bed using one 5/16-18 x 3-1/4 IN bolt and nut (25 & 26).

Note: For easier assembly place unit upside down

5. Tighten all nut and bolt assemblies. Be sure not to over tighten or crush tubing when tightening.
6. Slide assembly wheel/tire (3) onto spindle between two 45MM washers (16) and secure by inserting lock pin 6 x 40MM (19) through the end of the hex spindle (2).
7. Repeat Step 6 for the other side.

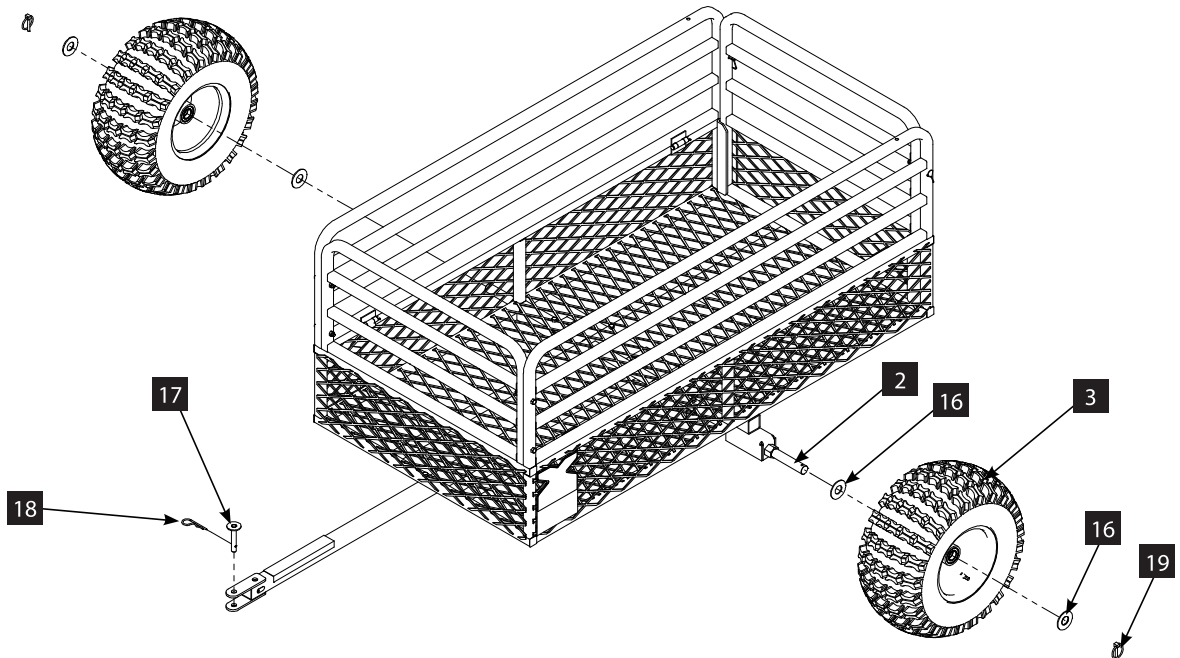

STEP 5-7

PARTS LIST

ITEM #	PART #	DESCRIPTION	QTY.
1	32783	SQ PLUG 25 MM	8
2	36338	HEX SPINDLE	2
3	36529	ASSEMBLY WHEEL/TIRE 18 X 9.5-8 IN	2
4	36721	TRAILER TONGUE	1
5	36725	AXLE	1
6	36731	TRAILER BED	1
7	36735	SIDE RAIL LEFT	1
8	36736	SIDE RAIL RIGHT	1
9	36737	FRONT RAIL	1
10	36740	TAILGATE	1
11	38758	PIN 8.45 X 65 MM	4
12	38759	WASHER 9.35 X 12.5 X 0.80 MM	4
13	38764	COTTER PIN 2 X 5 MM	4
14	48152	BOLT 5/16 X 18 X 1-1/2 IN	2
15	WF516B	WASHER 5/16 X 7/8 X 5/64 IN	2
16	36535	WASHER 25 X 45 X 2.40 MM	2
17	25033	HITCH PIN	1
18	12118	HAIRPIN 1/8 IN	1
19	37772	LOCK PIN 6 X 40 MM	2
20	36790	SNAP PIN 1/4 X 3 IN	2
21	36789	SPACER 8.1 X19 X 3.5 MM	2
22	8655B	BOLT 5/16 X18 X 1-3/4 IN	2
23	53730B	BOLT 5/16 X 18 X 2-1/2 IN	4
24	17949	BOLT 5/16 X 18 X 2-3/4 IN	1
25	27966	BOLT 5/16 X 18 X 3-1/4 IN	3
26	60G5NYB	NUT 5/16-18	10

OPTIONAL ACCESSORIES

PART #	DESCRIPTION
TX113	2" Ball Hitch Kit

ILLUSTRATED PARTS BREAKDOWN

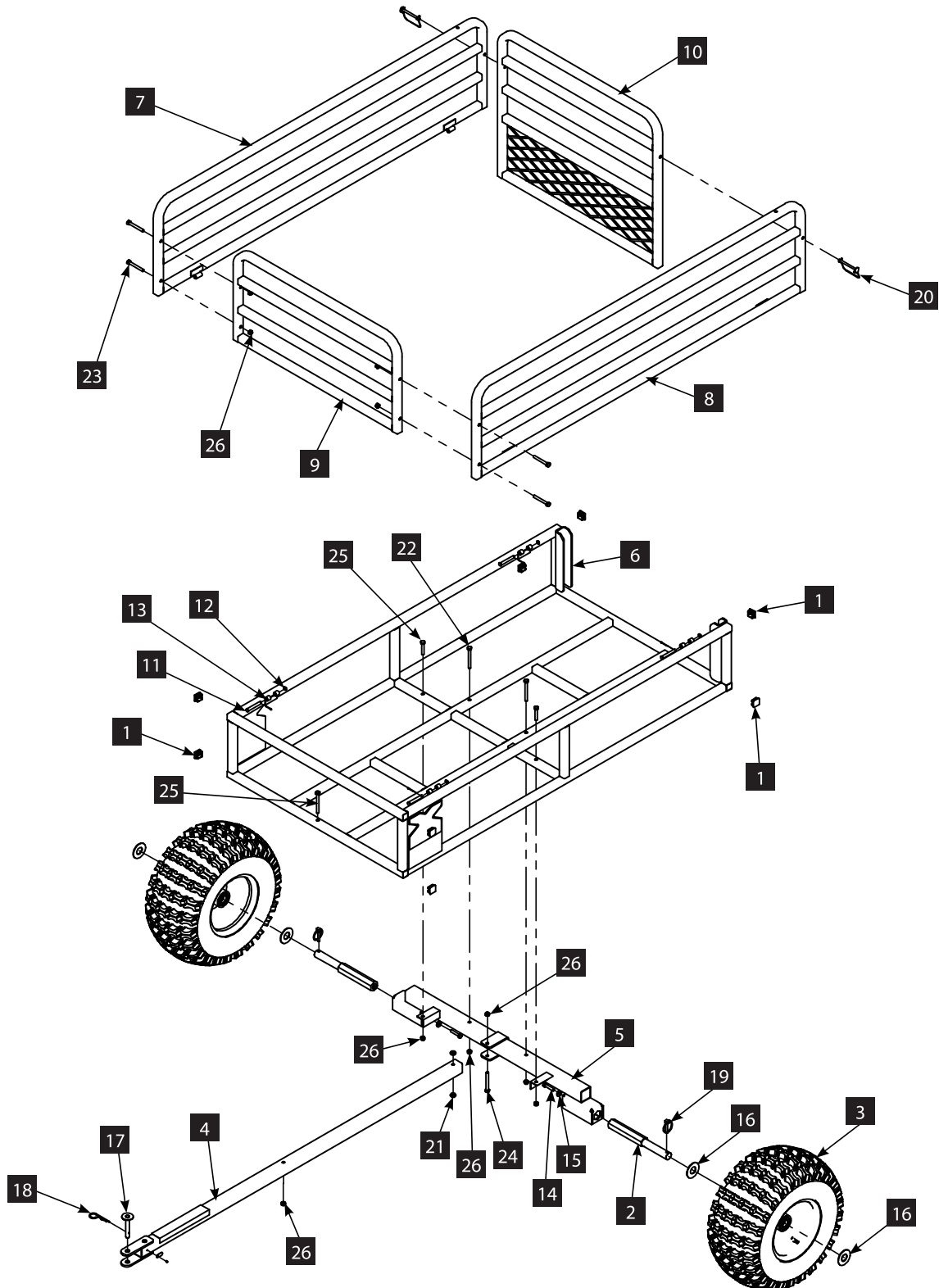

YUTRAX™



YUTRAX™, A Division of Ardisam, Inc.
1160 Eighth Avenue, PO Box 666
Cumberland, WI 54829

Phone: 800-345-6007
Fax: 715-822-2124
www.yutrax.com

*All weights, specifications and features are approximate and are subject to change without notice. Due to continuous product improvements, product images may not be exact. Warning labels in some product images may have been removed for photography purposes only. Props shown in photos not included. Some assembly may be required.